



PROJECT CONCEPT NOTE

CARBON OFFSET UNIT (CoU) PROJECT



Title: 3.0 MW Bundled Small Scale Wind Power Project by Energy Development Company Limited by Energy Advisory Services Pvt Ltd

Version 2.0

Date 18/05/2024

First CoU Issuance Period: 11 years, 0 months

Date: 01/01/2013 to 31/12/2023



BASIC INFORMATION	
Title of the project activity	3.0 MW Bundled Small Scale Wind Power Project by Energy Development Company Limited
Scale of the project activity	Small Scale
Completion date of the PCN	18/03/2023
Project participants	Project Proponent: M/s Energy Development Company Limited Aggregator: Energy Advisory Services Pvt. Ltd.
Host Party	India

Applied methodologies and standardized baselines	CDM UNFCCC Methodology AMS-I.D.: Grid connected renewable electricity generation version-18 & UCR Standard for Emission Factor
Sectoral scopes	01 Energy industries (Renewable/Non-Renewable Sources)
Estimated total amount of average GHG emission reductions per year	4,943tCO ₂ eq or 4,943CoUs
Estimated total amount of average GHG emission reductions for the entire monitoring period	54,378 tCO ₂ eq or 54,378 CoUs

SECTION A. Description of project activity

A.1. Purpose and general description of Carbon offset Unit (CoU) project activity >>

The Project Titled “3.0 MW Bundled Small Scale Wind Power Project by M/s Energy Development Company Limited” is a Wind based Power Project successfully commissioned by Karnataka Power Transmission Corporation Limited (KPTCL) and Chitradurga K73 operational since 30/09/2008 and Hassan H25 operational since 27/09/2007. The Project is owned by M/s Energy Development Company Limited (hereby to be called as Project Proponent, PP).

Purpose of the project activity:

The purpose of the project activity is to utilize renewable wind energy for generation of electricity. The project activity replaces anthropogenic emissions of greenhouse gasses (GHG's) into the atmosphere, by displacing the equivalent amount of electricity generation through the operation of existing fuel fossil fuel-based power plants and future capacity expansions connected to the grid. In the absence of the project activity the equivalent amount of electricity would have been generated from the fossil fuel-based power plant. Whereas the electricity generation from operation of Wind Energy Convertors (WEC's) is emission free. Commissioning dates of the Wind Turbine Generators installed are shown in the below table:

Sr. No.	RR. No	No. & Capacity	Commissioning Date
1	(Hassan H25) HSN/IPP-020	1 X 1500 kW	27/09/2007
2	(Chitradurga K73) ELP - 10	1 X 1500 kW	30/09/2008

The project will generate approximately 5,493MWh of electricity per annum. The net generated electricity from the project activity is for captive consumption by the project proponent. K 73 Wheeling agreement is signed between PP and Bangalore Electricity Supply Company Limited (BESCOM), H 25 Wheeling agreement is signed between PP and Chamundeshwari Electricity Supply Corporation Limited. The project activity has been helping in greenhouse gas (GHG) emission reduction by using renewable resources (wind energy) for generating power which otherwise would have been generated using grid mix power plants, which is dominated by fossil fuel based thermal power plants. The estimated annual average and the total CO₂e emission reduction by the project activity is expected to be 4,943t/CO₂, whereas actual emission reduction achieved during the first CoU period shall be submitted as a part of first monitoring and verification.

A.2 Do no harm or Impact test of the project activity>>

There are social, environmental, economic and technological benefits which contribute to sustainable development.

Social Benefits:

- The project activity will lead to the development of supporting infrastructure such as road network etc., in the wind park location, the access to which is also provided to the local population.
- The project activity will lead to alleviation of poverty by establishing direct and indirect benefits through employment generation and improved economic activities by strengthening the local grid of the state electricity utility.
- Use of a renewable source of energy reduces the dependence on imported fossil fuels and associated price variation thereby leading to increased energy security.

Environmental benefits:

- The project activity employs renewable energy sources for electricity generation instead of fossil fuel-based electricity generation which would have emitted gaseous, liquid and/or solid effluents/wastes.
- Being a renewable resource, using wind energy to generate electricity contributes to resource conservation. Thus, the project causes no negative impact on the surrounding environment and contributes to environmental well-being.

Economic benefits:

- The project activity requires temporary and permanent, skilled and semi-skilled manpower at the wind park; this will create additional employment opportunities in the region.
- The generated electricity will be fed into the NEWNE regional grid through local grid, thereby improving the grid frequency and availability of electricity to the local consumers (villagers & sub-urban habitants) which will provide new opportunities for industries and economic activities to be setup in the area thereby resulting in greater local employment, ultimately leading to overall development.

Technical benefits:

- Increased interest in wind energy projects will further push R&D efforts by technology providers to develop more efficient and better machinery in future.

A.3. Location of project activity >>

K 73 (Chitradurga) Location

Country: India

District Chitradurga

State: Karnataka

K73 (Longitude: E76° 26' 36" 4 & Latitude: N14° 05' 11 3)

H 25 (Hassan) Location

Country: India

District Hassan

State: Karnataka

H25 (Longitude: E76° 11 44' 2 & Latitude: N13 ° 11' 09" 3)

Representative Map of India



Location of installed turbines:

Sr. No.	RR. No	Village
1	HSN/IPP-020	Rangapur -kawal
2	ELP - 10	Elkumahalli

A.4. Technologies/measures >>

The bundled project activity consists of 2 Wind turbines of 1.5 MW * 2 Nos. = 3.0 MW manufactured and supplied by Suzlon Energy Limited. Main component of the windmill is explained below:

Main Tower

This is a very tall structure with a door and inside ladder at the bottom. The door is used to enter into the tower for operation and maintenance.

Blades

The WEGs are provided with three blades. The blades are self-supporting in nature made up of Fiber Reinforced Polyester. The blades are mounted on the hub.

Nacelle

The Nacelle is the one which contains all the major parts of a WEG. The nacelle is made up of thick rugged steel and mounted on a heavy slewing ring. Under normal operating conditions, the nacelle would be facing the upstream wind direction.

Hub

The Hub is an intermediate assembly between the wing and the main shaft of the wind turbine. Inside the hub, a system to actuate the aerodynamic brake is fitted. The hub is covered with a nose cone.

Main Shaft

The shaft is to connect the gearbox and the hub. Solid high carbon steel bars or cylinders are used as the main shaft. The shaft is supported by two bearings.

Some of the salient features of the project equipment can be found in the below mentioned table:

Parameter	S 82	
Operating	Blade Material	GRP
	Rated Power	1,500kW
	Cut-in Wind Speed	4.0 m/s
	Rated Wind Speed	12.5 m/s
	Cut-out Wind Speed	20 m/s
Rotor	Rotor Diameter	82 m
	Swept Area	5,281 m ²
Generator	Frequency	50
	Type	Asynchronous 4 Pole

A.5. Parties and project participants >>

Party (Host)	Participants/Aggregator
India	<p>NAME OF OWNER: Energy Development Company Limited, EDCL House, 1 A, Elgin Road, Kolkata 700020</p> <p>AGGREGATOR: Energy Advisory Services Pvt. Ltd. Bangalore, Karnataka. Email: manoj@easpl.co.in</p>

A.6. Baseline Emissions>>

The baseline scenario identified at the PCN stage of the project activity is:

- Grid

In the absence of the project activity, the equivalent amount of electricity would have been generated from fossil fuel-based power plants and exported to the southern regional grid (which is connected to the unified Indian Grid system) as the national grid is predominantly sourcing from fossil fuel-based power plants. Hence, the baseline scenario of the project activity is the grid-based electricity system, which is also the pre-project scenario.

Schematic diagram showing the baseline scenario:

Baseline Scenario:

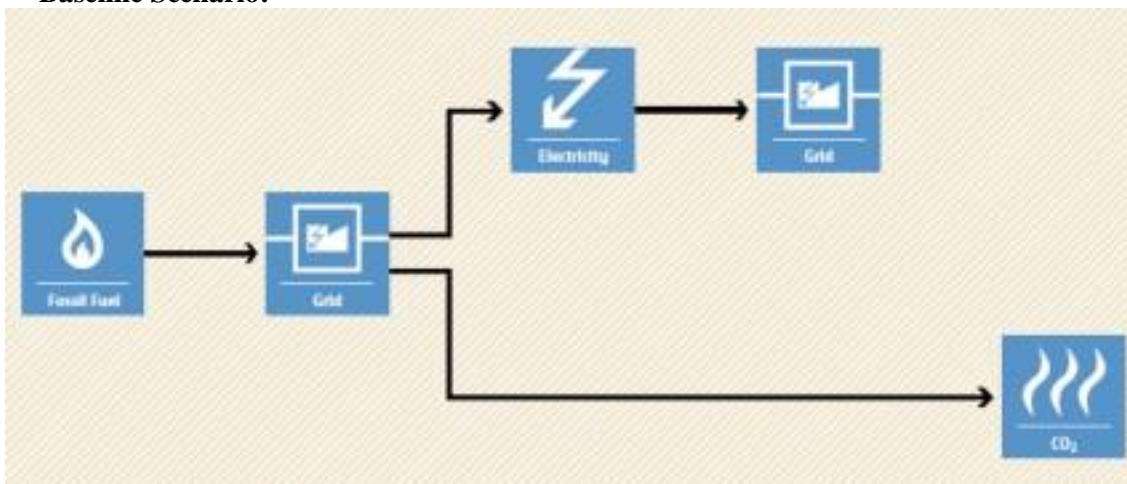

Project Scenario:

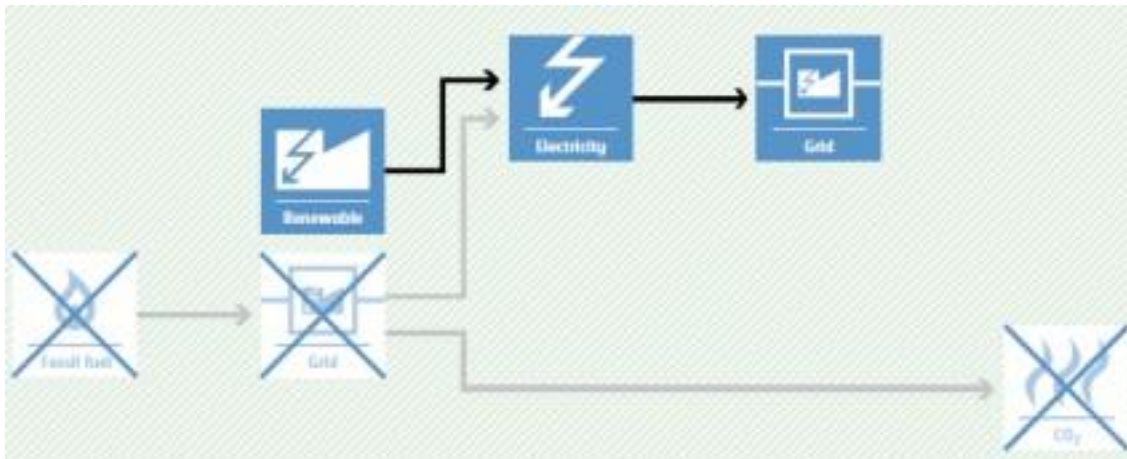

A.7. Debundling>>

This project is not a debundled component of a larger registered carbon offset project activity.

SECTION B. Application of methodologies and standardized baselines

B.1. References to methodologies and standardized baselines >>

SECTORAL SCOPE - 01 Energy industries (Renewable/Non-renewable sources)

TYPE I - Renewable Energy Projects

CATEGORY- AMS-I.D.: “Grid connected renewable electricity generation” Version-18

B.2. Applicability of methodologies and standardized baselines >>

The project activity involves generation of grid connected electricity from the construction and operation of a new wind power-based power project for captive consumption. The project activity has installed capacity of 3.0 MW which will qualify for a small-scale project activity under Type-I of the Small-Scale methodology. The project status is corresponding to the methodology AMS-I.D., version 18 and applicability of methodology is discussed below.

Applicability Criterion	Project Case
<p>1. This methodology comprises renewable energy generation units, such as photovoltaic, hydro, tidal/wave, wind, geothermal and renewable biomass:</p> <ul style="list-style-type: none">(a) Supplying electricity to a national or a regional grid; or(b) Supplying electricity to an identified consumer facility via national/regional grid through a contractual arrangement such as wheeling.	<p>The project activity is a Renewable Energy Project i.e., wind power project for captive consumption which falls under applicability criteria option 1 point (b). Thus, this project activity fulfills this criterion.</p>
<p>2. This methodology is applicable to project activities that:</p> <ul style="list-style-type: none">(a) Install a Greenfield plant;(b) Involve a capacity addition in (an) existing plant(s);(c) Involve a retrofit of (an) existing plant(s); (d) Involve a rehabilitation of (an) existing plant(s)/unit(s); or(e) Involve a replacement of (an) existing plant(s).	<p>The option (a) of applicability criteria 2 is applicable as the project is a Greenfield plant /unit. Hence the project activity meets the given applicability criterion.</p>

<p>3. Hydro power plants with reservoirs that satisfy at least one of the following conditions are eligible to apply this methodology:</p> <ul style="list-style-type: none"> (a) The project activity is implemented in existing reservoir, with no change in the volume of the reservoir; or (b) The project activity is implemented in existing reservoirs, where the volume of the reservoir(s) is increased and the power density as per definitions given in the project emissions section, is greater than 4 W/m². (c) The project activity results in new reservoirs and the power density of the power plant, as per definitions given in the project emissions section, is greater than 4 W/m² 	<p>The project activity involves installation of Wind Turbine Generators (WTGs); hence, this criterion is not applicable.</p>
<p>4. If the new unit has both renewable and non-renewable components (e.g., a wind/diesel unit), the eligibility limit of 15 MW for a small-scale CDM project activity applies only to the renewable component. If the new unit co-fires fossil fuel, the capacity of the entire unit shall not exceed the limit of 15 MW.</p>	<p>The proposed project is 3.0 MW Wind power project, i.e., only component is renewable power project below 15MW, thus the criteria is not applicable to this project activity.</p>
<p>5. Combined heat and power (co-generation) systems are not eligible under this category</p>	<p>The project activity is a wind power project thus the criterion is not applicable to this project activity.</p>

6. In the case of project activities that involve the capacity addition of renewable energy generation units at an existing renewable power generation facility, the added capacity of the units added by the project should be lower than 15 MW and should be physically distinct from the existing units.	The proposed project is a greenfield 3.0 MW wind power project. As no capacity addition is taking place thus the criterion is not applicable to this project activity.
7. In the case of retrofit, rehabilitation or replacement, to qualify as a small-scale project, the total output of the retrofitted, rehabilitated or replacement power plant/unit shall not exceed the limit of 15 MW.	The proposed project is a greenfield 3.0 MW wind power project. As this does not involve retrofit, rehabilitation or replacement, thus the criterion is not applicable to this project activity.
8. In the case of landfill gas, waste gas, wastewater treatment and agro-industries projects, recovered methane emissions are eligible under a relevant Type III category. If the recovered methane is used for electricity generation for supply to a grid, then the baseline for the electricity component shall be in accordance with procedure prescribed under this methodology. If the recovered methane is used for heat generation or cogeneration other applicable Type-I methodologies such as “AMS I.C.: Thermal energy production with or without electricity” shall be explored.	The proposed project is a greenfield 3.0 MW wind power project; hence, this criterion is not applicable to this project activity.
9. In case biomass is sourced from dedicated plantations, the applicability criteria in the tool “Project emissions from cultivation of biomass” shall apply.	No biomass is involved, the project is only a wind power project and thus the criterion is not applicable to this project activity.

B.3. Applicability of double counting emission reductions >>

There is no double accounting of emission reductions in the project activity due to the following reasons:

- Project is uniquely identifiable based on its location coordinates,
- Project has dedicated commissioning certificate and connection point,
- Project is associated with energy meters which are dedicated to the consumption point for project developer.

B.4. Project boundary, sources and greenhouse gases (GHGs)>>

As per applicable methodology AMS-I.D., Version 18.0, “The spatial extent of the project boundary includes the project power plant and all power plants connected physically to the electricity system that the project power plant is connected to.”

Thus, the project boundary includes the Wind Turbine Generator (WTG) and the Indian grid system.

Source		Gas	Included?	Justification/Explanation
.	Grid connected electricity	CO ₂	Yes	Main emission source
		CH ₄	No	Minor emission source

	generation	N ₂ O	No	Minor emission source
		Other	No	No other GHG emissions were emitted from the project
	Greenfield Wind Power Project Activity	CO ₂	No	No CO ₂ emissions are emitted from the project
		CH ₄	No	Project activity does not emit CH ₄
		N ₂ O	No	Project activity does not emit N ₂ O
		Other	No	No other emissions are emitted from the project

B.5. Establishment and description of baseline scenario >>

As per the approved consolidated methodology AMS-I.D. Version 18, if the project activity is the installation of a new grid-connected renewable power plant/unit, the baseline scenario is the following: **“The baseline scenario is that the electricity delivered to the grid by the project activity would have otherwise been generated by the operation of grid-connected power plants and by the addition of new generation sources into the grid”**

The project activity involves setting up a new Wind Power plant to harness the kinetic energy of flowing water. In the absence of the project activity, the equivalent amount of power would have been supplied by the Indian grid, which is fed mainly by fossil fuel-fired plants. Hence, the baseline for the project activity is the equivalent amount of power produced at the Indian grid.

A "grid emission factor" refers to a CO₂ emission factor (tCO₂/MWh) that will be associated with each unit of electricity provided by an electricity system. The UCR recommends an emission factor of 0.9 tCO₂/MWh for the 2013-2023 years as a conservative estimate for Indian projects not previously verified under any GHG program. Also, for the vintage 2022-2023, the combined margin emission factor calculated from the CEA database in India results in higher emissions than the default value. Hence, the same emission factor has been considered to calculate the emission reduction under a conservative approach.

B.1.1 Net GHG Emission Reductions and Removals

Thus, $ER_y = BE_y - PE_y - LE_y$

Where:
 ER_y = Emission reductions in year y (tCO₂/y)
 BE_y = Baseline Emissions in year y (t CO₂/y)
 PE_y = Project emissions in year y (tCO₂/y)
 LE_y = Leakage emissions in year y (tCO₂/y)

- **Baseline Emissions**

Baseline emissions include only CO₂ emissions from electricity generation in power plants that are displaced due to the project activity. The methodology assumes that all project electricity generation above baseline levels would have been generated by existing grid-connected power plants and the addition of new grid-connected power plants.

The baseline emissions are to be calculated as follows:

$$BE_y = EG_{PJ,y} \times EF_{grid,y}$$

BE_y = Baseline emissions in year y (t CO₂)

$EG_{PJ,y}$ = Quantity of net electricity generation that is produced and fed into the grid as a result of the implementation of the CDM project activity in year y (MWh)

$EF_{grid,y}$ = UCR recommended emission factor of **0.9 tCO₂/MWh** has been considered. (Reference: General Project Eligibility Criteria and Guidance, UCR Standard, page 4)

Estimated annual baseline emission reductions (BE_y)

$$\begin{aligned} &= 5,493\text{MWh/year} * 0.90 \text{ tCO}_2/\text{MWh} \\ &= 4,943\text{tCO}_2/\text{y} \end{aligned}$$

• Project Emissions Calculation

As per Paragraph 39 of AMS-I.D. version-18, only emissions associated with fossil fuel combustion, emissions from the operation of geothermal power plants due to the release of non-condensable gases, and emissions from a Wind should be accounted for the project emission. Since the project activity is a Wind power project, project emission for renewable energy plants is nil.

Thus, PE = 0

• Leakage Emission Calculation

As per paragraph 42 of AMS-I.D. version-18, 'If the energy generating equipment is transferred from another activity, leakage is to be considered.' In the project activity, there is no transfer of energy generating equipment and therefore the leakage from the project activity is considered zero.

Hence, LE = 0

• Net Emission

The actual emission reduction achieved during the first CoU period shall be submitted as a part of the first monitoring and verification. However, for the purpose of an ex-ante estimation, the following calculation has been submitted:

Hence,

Net GHG emission reduction, = **4,943-0-0 = 4,943tCO₂** (i.e., **4,943CoUs**)

B.2. Prior History>>

The project activity is a small-scale Wind project and was not applied under any other GHG mechanism prior to this registration with UCR. Also, the project has not been applied for any other environmental crediting or certification mechanism.

Hence the project will not cause double accounting of carbon credits (i.e., CoUs).

B.7. Changes to start date of crediting period >>

There is no change in the start date of crediting period.

The start date of crediting under UCR is considered as 01/01/2013, which is the project's first monitoring date.

B.8. Permanent changes from PCN monitoring plan, applied methodology or applied standardized baseline >>

There are no permanent changes from registered PCN monitoring plan and applied methodology.

B.9. Monitoring period number and duration>>

First Issuance Period: 11 years, 0 months – 01/01/2013 to 31/12/2023

B.8. Monitoring plan>>

USE THE FOLLOWING TABLES TO FOR PARAMETERS BEING MONITORED OR USED IN EMISSION REDUCTIONS DETERMINATION

Parameter	$EG_{PJ,y}$
Data unit	MWh
Description	Quantity of net electricity generation that is produced and fed into the grid because of the implementation of this project activity in year y.
Source of data Value(s) applied	Monthly Joint meter reading documents.
Procedures	The Net electricity generation by the Wind power plant is recorded at the sub-station. At the end of every month Electrical distribution company notes down the meter readings and generate the joint meter reading (JMR) report based on the monthly electricity exported to the grid or consumed by the nearby local community.
Monitoring frequency	Monthly
Purpose of data	To calculate the baseline emission

Parameter	$EF_{grid,y}$
Data and Parameters available at validation (ex-ante values)	UCR recommended emission factor
Data unit	tCO ₂ /MWh
Description	A "grid emission factor" refers to a CO ₂ emission factor (tCO ₂ /MWh) which will be associated with each unit of electricity provided by an electricity system. The UCR recommends an emission factor of 0.9 tCO ₂ /MWh for the 2016 - 2022 years as a conservative estimate for Indian projects not previously verified under any GHG program. Hence, the same emission factor has been considered to calculate the emission reduction under conservative approach.
Source of data	https://cea.nic.in/wp-content/uploads/baseline/2023/01/Approved_report_emission_2022_23.pdf and UCR Document
Value applied	0.9
Measurement methods and procedures	-
Monitoring frequency	Ex-ante fixed parameter
Purpose of Data	For the calculation of Emission Factor of the grid
Additional Comment	The combined margin emission factor as per CEA database (current version 19, Year 2023) results into higher emission factor. Hence for 2023 vintage UCR default emission factor remains conservative.

Data/Parameter	Date of commissioning of the units
Data unit	Date
Description	Actual date of commissioning of the project unit
Source of data Value(s) applied	Commissioning report issued by State grid transmission corporation or State electricity board
Measurement methods and procedures	The construction processes are maintained from its initiation to completion dates for the Wind unit. Thus, the start date of each of the unit installed is recorded in the monitoring report.
Monitoring frequency	As and when commissioned and fixed and recorded in the monitoring report
Purpose of data	To estimate baseline emissions